

ALBION®

// 310 & 410 KINGPINLESS HEAVY-DUTY INDUSTRIAL CASTERS

SUPERIOR STRENGTH FOR RUGGED APPLICATIONS

////// **85% of Caster Failures** are at the **Kingpin**
Albion Kingpinless Casters
Eliminate Kingpin Failure.

- Forged Raceway
- Ergonomic Performance
- Dual Wheel and Spring-Load options available
- Laser Cut 3/8" Thick Legs
- Impact and Shock Durability
- Zinc-Plated, plus Clear Coat
- Capacity up to 5,400 lbs
- Heat-Treated AISI 1045 steel



410 Series
Top-Plate Swivel



310 Swivel
Integrated PLM Brake



410 Swivel
Poly Cam Brake

310 Dual Wheel
Kingpinless



410 Swivel
Spring Loaded



310 Swivel
with Toe Guard
and PLB Brake



REQUEST SAMPLES OR QUOTES
ALBIONCASTERS.COM

HEAVY DUTY KINGPINLESS CASTERS

CAPACITY UP TO 5,400 LBS

Common Applications:

- Conveyor-Drawn Tow-Trucks
- Heavy Duty Bakery Racks
- Production Dollies
- Heavy Duty Dough Troughs
- Body Dolly Carts
- Engine Dollies
- Material Carts
- Aircraft Maintenance Stands
- Aircraft Engine Stands



Kingpinless Casters **ELIMINATE** KINGPIN FAILURE

Kingpinless casters are ideal for power-towed applications, handling shock and impact better than traditional kingpin casters. Their precision-machined raceway with ball bearings ensures smoother swiveling, greater load distribution, and eliminates the primary failure point found in conventional swivel designs.

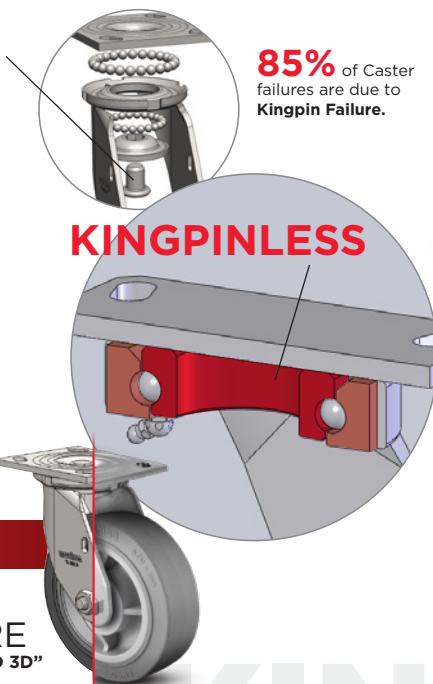

85% of Caster failures are due to Kingpin Failure.



Albion 310 Series
Heavy Duty
Kingpinless Caster

Albion 410 Series
Heavy Duty
Kingpinless Caster

DOWNLOAD
3D CAD MODELS
& DATASHEETS

ONLINE APP STORE
AlbionCasters.com Search: "Caster CAD 3D"

KINGPINLESS

CASTER COMPONENTS

RIG CONSTRUCTION

KINGPIN RIG

CONVENTIONAL CONSTRUCTION

• UP TO 2,000 LB. CAPACITY

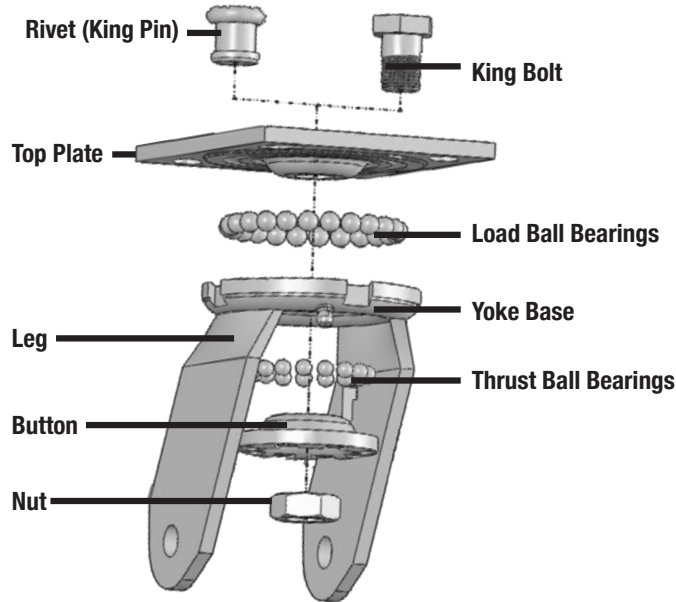

KINGPINLESS RIG

BETTER ERGONOMICS, BEST FOR SHOCK AND IMPACT

• UP TO 20,000 LBS. CAPACITY

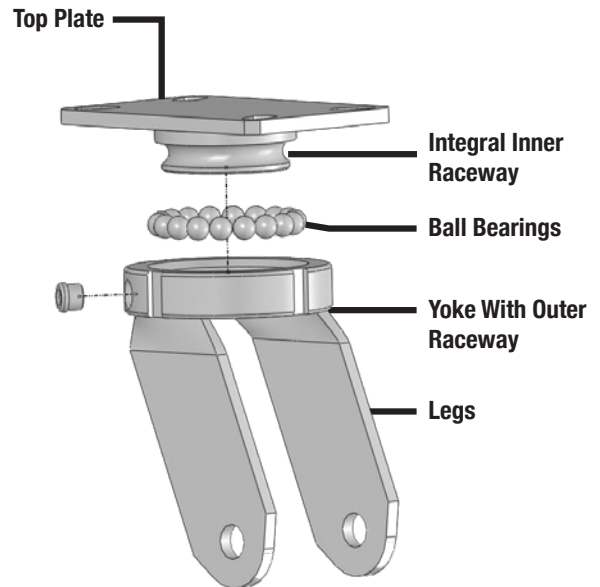

WHEEL CONSTRUCTION

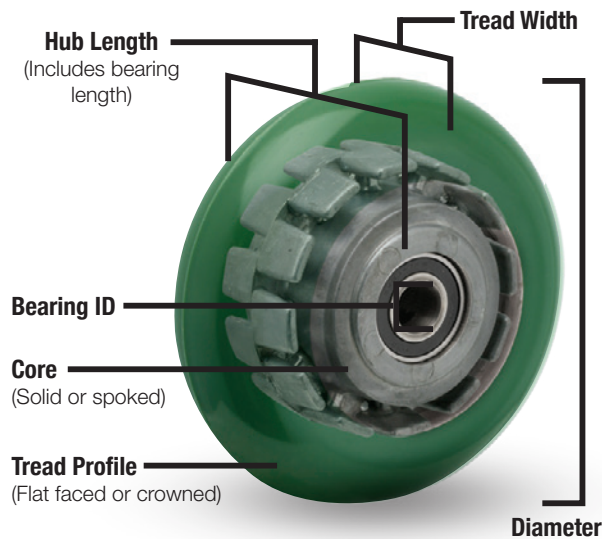

ALBION[®]
the caster experts

Need help determining the right solution for your application?

Let us help! Connect with us online at www.albioncasters.com

or call us at 800-835-8911.

310

Kingpinless Casters

CAPACITY TO 4100 LBS



Constructed from high quality, heat treated AISI 1045 laser-cut steel. Precision machined race-way, fully welded legs (inside and outside), and kingpinless design delivers superior strength in rugged applications.

TYPICAL APPLICATIONS

- Conveyor-drawn tow-trucks
- Heavy duty bakery racks
- Production dollies
- Heavy duty dough troughs

SWIVEL CROSS SECTION



MOUNTING OPTIONS

Standard Plate

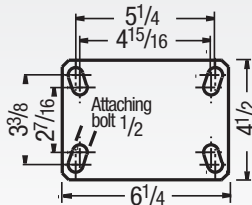

Special Order Plate

Optional (PATP)

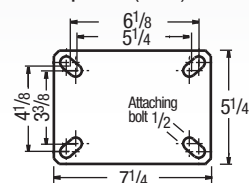

For optional plates consult factory

Base Swivel Caster Number In Chart
For rigid models change "S" to "R" at end of base caster number.

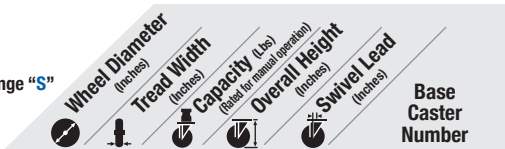

POLYURETHANE MODELS

CG-MAX EFFICIENCY WHEEL™ Maroon Round Polyurethane on Aluminum

AX	10	2	3100	12	3 1/2	310AX10228S
						85 Shore A
						Standard Bearing: Precision Ball (28)
						Overall height is 12" for 10x2 wheels only.

CG-MAX EFFICIENCY WHEEL™ Orange Round Polyurethane on Aluminum

AN	10	2	3100	12	3 1/2	310AX10228S
						85 Shore A
						Standard Bearing: Precision Ball (28)
						Overall height is 12" for 10x2 wheels only.



Premium Quality



Towing[^]



Environmentally Friendly
(Consult factory)

FEATURES

- Integral laser cut design
- 3 Year warranty
- Top Plate: 5/16" AISI 1045
- Swivel Section: One row of 1/2" ball bearings mounted in a heat treated precision machined race-way. Zerk in swivel section
- Yoke Base: Notched AISI 1045 steel
- Legs: 3/8" thick welded inside and out
- Axle: 3/4" diameter
- Finish: RoHS Zinc plating, for greater corrosion resistance than paint
- Alternate or custom caster configurations available

RIG OPTIONS

- **Optional Towable Swivel Leads:** Consult factory for optional towing leads
- **Optional Spring Loaded:** Spring loaded casters offer improved product protection and reduce noise. See options available on page 87

ACCESSORIES

To order, add brake code below to end of model. Example: 310PY08401SP

Poly Cam brake specify **P**



PLB Integrated brake specify **PLB**

Face brake specify **FBB**



Face brake specify **F**

Hand operated field installable **swivel lock** order **SL3000000** separately



BEARING OPTIONS

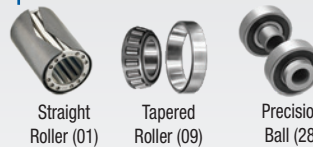

TOE GUARD

Specify **TO** for caster integrated toe guard. Standard model toe guards are 1/2" from the floor.



STAINLESS STEEL OPTION

See page 41



Field installable toe guards See page 23 for model numbers

Base Swivel Caster Number In Chart
For rigid models change "S" to "R" at end of base caster number.

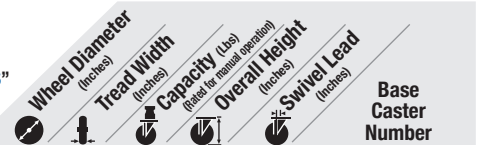

POLYURETHANE MODELS (CONTINUED)

Polyurethane on Cast Iron

PY	6	3	2200	7 1/2	1 3/8	310PY06501S
	8	3	2600	10 1/8	2 1/16	310PY08501S
	10	3	3100	11 1/2	2 1/4	310PY10501S
	12	3	3600	13 1/2	2 11/16	310PY12501S
						95 Shore A
						Standard Bearing: Roller (01).
						Optional Bearing: Tapered Roller (09);
						Change 01 above to 09.
						Consult PY section on pages 104-105 for optional durometers/capacities

Thick Tread Polyurethane on Cast Iron

PX	6	3	2450	7 1/2	1 3/8	310PX06501S
	8	3	3500	10 1/8	2 1/16	310PX08501S
	10	3	3700	11 1/2	2 1/4	310PX10501S
	12	3	4100	13 1/2	2 11/16	310PX12501S
						95 Shore A
						Standard Bearing: Roller (01).
						Optional Bearing: Tapered Roller (09); Change 01 above to 09.
						Standard durometer 95 Shore A. Other durometers available.

[^]Towing: Consult factory prior to ordering to ensure selection supports your towing requirement

310 Series Continued

Base Swivel Caster
Number In Chart
For rigid models change "S"
to "R" at end of base
caster number.

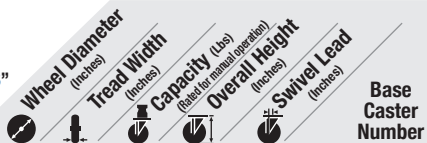

POLYURETHANE MODELS (CONTINUED)

Polyurethane Reactive on Cast Iron

AZ	Wheel Diameter (inches)	Tread Width (inches)	Capacity (lbs)	Overall Height (inches)	Swivel Lead (inches)	Base Caster Number
	6	3	1800	7 1/2	1 3/8	310AZ06528S
	8	3	2000	10 1/8	2 1/16	310AZ08528S
	10	3	2200	11 1/2	2 1/4	310AZ10528S
	12	3	2400	13 1/2	2 11/16	310AZ12528S

80 Shore A Standard Bearing: Precision Ball (28).

Yellow Polyurethane on Heavy Duty Cast Iron

PF	Wheel Diameter (inches)	Tread Width (inches)	Capacity (lbs)	Overall Height (inches)	Swivel Lead (inches)	Base Caster Number
	6	3	3300	7 1/2	1 3/8	310PF06528S
	8	3	4000	10 1/8	2 1/16	310PF08528S
	10	3	4100	11 1/2	2 1/4	310PF10528S
	12	3	4100	13 1/2	2 11/16	310PF12528S

95 Shore A Standard Bearing: Precision Ball (28).

Aubin Industries Swivel-EAZ® Crown Tread

EY	Wheel Diameter (inches)	Tread Width (inches)	Capacity (lbs)	Overall Height (inches)	Swivel Lead (inches)	Base Caster Number
	6	3	2137	7 1/2	1 3/8	310EY06528S
	8	3	3250	10 1/8	2 1/16	310EY08528S
	10	3	3800	11 1/2	2 1/4	310EY10528S
	12	3	4000	13 1/2	2 11/16	310EY12528S

95 Shore A Standard Bearing: Precision Ball (28).
Standard durometer 95 Shore A. Other durometers available.

Aubin Industries Swivel-EAZ® Flat Tread

EZ	Wheel Diameter (inches)	Tread Width (inches)	Capacity (lbs)	Overall Height (inches)	Swivel Lead (inches)	Base Caster Number
	6	3	2850	7 1/2	1 3/8	310EZ06528S
	8	3	4000	10 1/8	2 1/16	310EZ08528S
	10	3	4100	11 1/2	2 1/4	310EZ10528S
	12	3	4100	13 1/2	2 11/16	310EZ12528S

95 Shore A Standard Bearing: Precision Ball (28).
Standard durometer 95 Shore A. Other durometers available.

Polyurethane on Aluminum

PD	Wheel Diameter (inches)	Tread Width (inches)	Capacity (lbs)	Overall Height (inches)	Swivel Lead (inches)	Base Caster Number
	8	3	2520	10 1/8	2 1/16	310PD08501S
	10	3	3000	11 1/2	2 1/4	310PD10501S
	12	3	3500	13 1/2	2 11/16	310PD12501S

95 Shore A Standard Bearing: Roller (01).
Optional Bearing: Tapered Roller (09); Change 01 above to 09.

NYLON MODELS

Trionix™ High Impact Polymer

NX	Wheel Diameter (inches)	Tread Width (inches)	Capacity (lbs)	Overall Height (inches)	Swivel Lead (inches)	Base Caster Number
	6	3	4100	7 1/2	1 3/8	310NX06528S
	8	3	4100	10 1/8	2 1/16	310NX08528S
	10	3	4100	11 1/2	2 1/4	310NX10528S
	12	3	4100	13 1/2	2 11/16	310NX12528S

Standard Bearing: Precision Ball (28).

Base Swivel Caster
Number In Chart
For rigid models change "S"
to "R" at end of base
caster number.



METAL MODELS

Drop Forged Steel

FS	Wheel Diameter (inches)	Tread Width (inches)	Capacity (lbs)	Overall Height (inches)	Swivel Lead (inches)	Base Caster Number
	6	3	4100	7 1/2	1 3/8	310FS06501S
	8	3	4100	10 1/8	2 1/16	310FS08501S
	10	3	4100	11 1/2	2 1/4	310FS10501S

Standard Bearing: Roller (01).
Optional Bearings: Tapered Roller (09); Change 01 above to 09.

Crowned Tread Ductile Iron

FR, VM	Wheel Diameter (inches)	Tread Width (inches)	Capacity (lbs)	Overall Height (inches)	Swivel Lead (inches)	Base Caster Number
	6	3	4100	7 1/2	1 3/8	310FR06501S
	8	3	4100	10 1/8	2 1/16	310FR08501S
	10	3	4100	11 1/2	2 1/4	310FR10501S
	12	3	4100	13 1/2	2 11/16	310FR12501S

Standard Bearing: Roller (01).
Optional Bearings: Tapered Roller (09); Change 01 above to 09.
V-Groove (VM) models available.
Change FR wheel code to VM. Example: 310VM08501S.
VM is not available in 12" diameter

Cast Iron

CA	Wheel Diameter (inches)	Tread Width (inches)	Capacity (lbs)	Overall Height (inches)	Swivel Lead (inches)	Base Caster Number
	6	3	2800	7 1/2	1 3/8	310CA06501S
	8	3	2800	10 1/8	2 1/16	310CA08501S
	10	3	2800	11 1/2	2 1/4	310CA10501S
	12	3	2800	13 1/2	2 11/16	310CA12501S

Standard Bearing: Roller (01).
Optional Bearings: Tapered Roller (09); Change 01 above to 09.

Drop Forged V-Grooved

VF	Wheel Diameter (inches)	Tread Width (inches)	Capacity (lbs)	Overall Height (inches)	Swivel Lead (inches)	Base Caster Number
	8	3	4100	10 1/8	2 1/16	310VF08501S
	10	3	4100	11 1/2	2 1/4	310VF10501S

Standard Bearing: Roller (01).

V-Groove Cast Iron

VG	Wheel Diameter (inches)	Tread Width (inches)	Capacity (lbs)	Overall Height (inches)	Swivel Lead (inches)	Base Caster Number
	6	2 1/2	2500	7 1/2	1 3/8	310VG06401S
	8	2 1/2	2500	10 1/8	2 1/16	310VG08401S
	8	3	2500	10 1/8	2 1/16	310VG08501S
	10	3	3500	11 1/2	2 1/4	310VG10501S

Standard Bearing: Roller (01).
Optional Bearings: Tapered Roller (09); Change 01 above to 09.

PHENOLIC MODELS

Phenolic

TM	Wheel Diameter (inches)	Tread Width (inches)	Capacity (lbs)	Overall Height (inches)	Swivel Lead (inches)	Base Caster Number
	6	3	2000	7 1/2	1 3/8	310TM06501S
	8	3	2500	10 1/8	2 1/16	310TM08501S
	10	3	2900	11 1/2	2 1/4	310TM10501S
	12	3	3500	13 1/2	2 11/16	310TM12501S

Standard Bearing: Roller (01).
Optional Bearings: Tapered Roller (09); Change 01 above to 09.

Selecting The Right Heavy Duty Wheel For Your Application



PY PX

- Our standard, versatile polyurethane formulation
- Introductory capacity range of our premium wheel offering
- PX features thicker tread for greater capacity



PD

- Aluminum core provides improved corrosion resistance
- Lighter weight than heavy cast iron cores



AZ PF EY EZ

- High capacity formulation
- Excellent ergonomic performance
- Standard precision ball bearing



NX

- High capacity and impact strength
- Best steel wheel replacement for added floor protection



TM

- High load capacities
- Impact resistant
- Economical
- High-temp options

410

Kingpinless Casters

CAPACITY TO 5400 LBS



Premium Quality



Towing[^]



Environmentally Friendly
(Consult factory)



Constructed from high quality, heat treated AISI 1045 laser-cut steel. Precision machined race-way, fully welded legs (inside and outside), and kingpinless design delivers superior strength in rugged applications.

MOUNTING OPTIONS Standard Plate

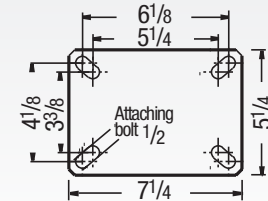

Special Order Plate

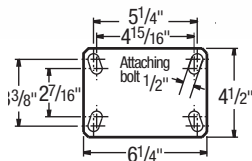

For optional plates consult factory

TYPICAL APPLICATIONS

- Conveyor-drawn tow-trucks
- Heavy duty bakery racks
- Production dollies
- Heavy duty dough troughs

SWIVEL CROSS SECTION

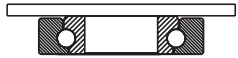

FEATURES

- **Integral laser cut design**
- **3 Year warranty**
- **Top Plate:** 3/8" AISI 1045
- **Swivel Section:** One row of 1/2" ball bearings mounted in a heat treated precision machined race-way. Zerk in swivel section
- **Yoke Base:** Notched AISI 1045 steel
- **Legs:** 3/8" thick welded inside and out
- **Axle:** 3/4" diameter
- **Finish:** RoHS Zinc plating, for greater corrosion resistance than paint
- Alternate or custom caster configurations available

RIG OPTIONS

- **Optional Spring Loaded:** Spring loaded casters offer improved product protection and reduce noise. See options available on page 86



ACCESSORIES

To order, add brake code below to end of model. Example: 410PY08501SP

Poly Cam brake
specify **P**



PLB Integrated brake
specify **PLB**

Face brake
specify **FBB**



Face brake
specify **F**

Hand operated field installable **swivel lock** order **SL4000000** separately



Field installable toe guards See page 23 for model numbers

BEARING OPTIONS

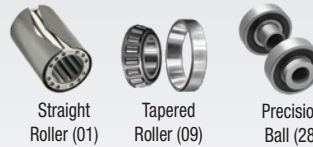

TOE GUARD

Specify **TO** for caster integrated toe guard. Standard model toe guards are 1/2" from the floor.



Base Swivel Caster Number In Chart
For rigid models change "S" to "R" at end of base caster number.

Wheel Diameter (Inches)	Tread Width (Inches)	Capacity (Lbs) (Based on manual operation)	Overall Height (Inches)	Swivel Lead (Inches)	Base Caster Number
-------------------------	----------------------	--	-------------------------	----------------------	--------------------

POLYURETHANE MODELS (CONTINUED)

Thick Tread Polyurethane on Cast Iron

PX	Wheel Diameter (Inches)	Tread Width (Inches)	Capacity (Lbs)	Overall Height (Inches)	Swivel Lead (Inches)	Base Caster Number
	6	3	2450	8	27/32	410PX06501S
	8	3	3500	10 1/2	215/16	410PX08501S
	10	3	3700	12 1/2	33/8	410PX10501S
	12	3	4100	15 1/2	45/16	410PX12501S

Standard Bearing: Roller (01).

Optional Bearing: Tapered Roller (09); Change 01 above to 09.

Polyurethane Reactive on Iron

AZ	Wheel Diameter (Inches)	Tread Width (Inches)	Capacity (Lbs)	Overall Height (Inches)	Swivel Lead (Inches)	Base Caster Number
	6	3	1800	8	27/32	410AZ06528S
	8	3	2000	10 1/2	215/16	410AZ08528S
	10	3	2200	12 1/2	33/8	410AZ10528S
	12	3	2400	15 1/2	45/16	410AZ12528S

80 Shore A

Standard Bearing: Precision Ball (28).

Base Swivel Caster Number In Chart
For rigid models change "S" to "R" at end of base caster number.

Wheel Diameter (Inches)	Tread Width (Inches)	Capacity (Lbs) (Based on manual operation)	Overall Height (Inches)	Swivel Lead (Inches)	Base Caster Number
-------------------------	----------------------	--	-------------------------	----------------------	--------------------

POLYURETHANE MODELS

Polyurethane on Cast Iron

PY	Wheel Diameter (Inches)	Tread Width (Inches)	Capacity (Lbs)	Overall Height (Inches)	Swivel Lead (Inches)	Base Caster Number
	6	3	2200	8	27/32	410PY06501S
	8	3	2600	10 1/2	215/16	410PY08501S
	10	3	3100	12 1/2	33/8	410PY10501S
	12	3	3600	15 1/2	45/16	410PY12501S

Standard Bearing: Roller (01).

Optional Bearing: Tapered Roller (09); Change 01 above to 09.

Consult PY section on pages 104-105 for optional durometers/capacities

[^]Towing: Consult factory prior to ordering to ensure selection supports your towing requirement

410 Series Continued

Base Swivel Caster Number In Chart
For rigid models change "S" to "R" at end of base caster number.

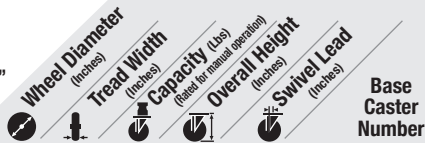

POLYURETHANE MODELS (CONTINUED)

Yellow Polyurethane on Heavy Duty Cast Iron

PF 	6	3	3300	8	27/32	410PF06528S
	8	3	4000	10 1/2	2 15/16	410PF08528S
	10	3	4200	12 1/2	3 3/8	410PF10528S
	12	3	4400	15 1/2	3 3/8	410PF12528S

95 Shore A Standard Bearing: Precision Ball (01).
 Optional Bearing: Tapered Roller (09); Change 01 above to 09.

Aubin Industries Swivel-EAZ® Round Tread

EY 	6	3	2137	8	27/32	410EY06528S
	8	3	3250	10 1/2	2 15/16	410EY08528S
	10	3	3800	12 1/2	3 3/8	410EY10528S
	12	3	4000	15 1/2	4 5/16	410EY12528S

Standard Bearing: Precision Ball (28).
 Optional Bearing: Tapered Roller (09); Change 28 above to 09.

Aubin Industries Swivel-EAZ® Flat Tread

EZ 	6	3	2850	8	27/32	410EZ06528S
	8	3	4000	10 1/2	2 15/16	410EZ08528S
	10	3	4800	12 1/2	3 3/8	410EZ10528S
	12	3	5400	15 1/2	4 5/16	410EZ12528S

Standard Bearing: Precision Ball (28).
 Optional Bearing: Tapered Roller (09); Change 28 above to 09.

Polyurethane on Aluminum

PD 	8	3	2520	10 1/2	2 15/16	410PD08501S
	10	3	3000	12 1/2	3 3/8	410PD10501S
	12	3	3500	15 1/2	3 3/8	410PD12501S

Standard Bearing: Roller (01).
 Optional Bearing: Tapered Roller (09); Change 01 above to 09.

NYLON MODELS

Trionix™ High Impact Polymer

NX 	6	3	5400	8	27/32	410NX06528S
	8	3	5400	10 1/2	2 15/16	410NX08528S
	10	3	5400	12 1/2	3 3/8	410NX10528S
	12	3	5400	15 1/2	4 5/16	410NX12528S

Standard Bearing: Precision Ball (28).
 Optional Bearing: Tapered Roller (09); Change 28 above to 09.

Base Swivel Caster Number In Chart
For rigid models change "S" to "R" at end of base caster number.

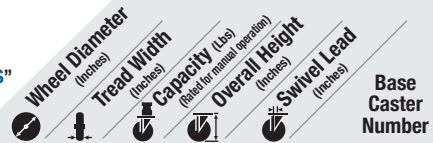

METAL MODELS

Drop Forged Steel

FS 	6	3	5400	8	27/32	410FS06501S
	8	3	5400	10 1/2	2 15/16	410FS08501S
	10	3	5400	12 1/2	3 3/8	410FS10501S

Standard Bearing: Roller (01).
 Optional Bearing: Tapered Roller (09); Change 01 above to 09.
 6x2-1/2 capacity increases to 5000, 8x3 capacity increases to 5400 and 10x3 capacity increases to 5400 with use of 09 bearing.

Crowned Tread Ductile Iron

FR, VM 	6	3	5400	8	27/32	410FR06501S
	8	3	5400	10 1/2	2 15/16	410FR08501S
	10	3	5400	12 1/2	3 3/8	410FR10501S

Standard Bearing: Roller (01).
 Optional Bearing: Tapered Roller (09); Change 01 above to 09.
 Ductile Iron V-Groove (VM) models available.
 Change FR wheel code to VM. Example: 410VM06401S.

Cast Iron

CA 	6	3	2800	8	27/32	410CA06501S
	8	3	2800	10 1/2	2 15/16	410CA08501S
	10	3	2800	12 1/2	3 3/8	410CA10501S
	12	3	2800	15 1/2	4 5/16	410CA12501S

Standard Bearing: Roller (01).
 Optional Bearing: Tapered Roller (09); Change 01 above to 09.

Drop Forged V-Grooved

VF 	8	3	5400	10 1/2	2 15/16	410VF08509S
	10	3	5400	12 1/2	3 3/8	410VF10509S

Standard Bearing: Roller (01).

V-Grooved Cast Iron

VG 	6	2 1/2	2500	8	27/32	410VG06401S
	8	2 1/2	2500	10 1/2	2 15/16	410VG08401S
	10	3	2500	12 1/2	2 15/16	410VG08501S
	12	3	2500	15 1/2	3 3/8	410VG10501S

Standard Bearing: Roller (01).
 Optional Bearing: Tapered Roller (09); Change 01 above to 09.

PHENOLIC MODELS

Phenolic

TM 	6	3	2000	8	27/32	410TM06501S
	8	3	2500	10 1/2	2 15/16	410TM08501S
	10	3	2900	12 1/2	3 3/8	410TM10501S
	12	3	3500	15 1/2	4 5/16	410TM12501S

Standard Bearing: Roller (01).
 Optional Bearing: Tapered Roller (09); Change 01 above to 09.

Selecting The Right Heavy Duty Wheel For Your Application



PY PX

- Our standard, versatile polyurethane formulation
- Introductory capacity range of our premium wheel offering
- PX features thicker tread for greater capacity



PD

- Aluminum core provides improved corrosion resistance
- Lighter weight than heavy cast iron cores



AZ PF EY EZ

- High capacity formulation
- Excellent ergonomic performance
- Standard precision ball bearing



NX

- High capacity and impact strength
- Best steel wheel replacement for added floor protection



TM

- High load capacities
- Impact resistant
- Economical
- High-temp options

ALBION®

// THE CASTER EXPERTS



Free CAD MODELS & DATASHEETS

EXPLORE • DOWNLOAD • SHARE

Explore Online

// Visit AlbionCasters.com

or On-the-Go



// Search "Caster CAD 3D"

- // Quickly configure models
- // Download native CAD formats
- // Download datasheets
- // Easily share with your team

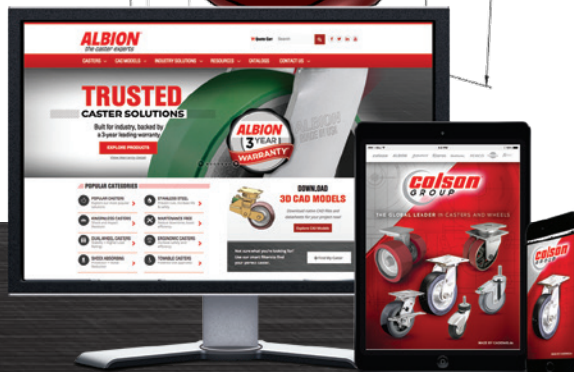
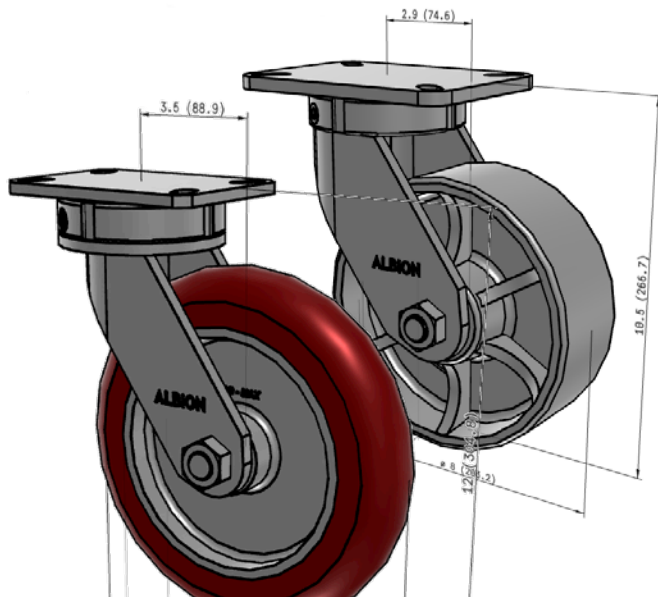

— A BRAND OF —
colson GROUP THE GLOBAL LEADER
IN CASTERS AND WHEELS

© Copyright 2025 | Colson Group | ColsonGroup.com
All product and brand names are trademarks and
the property of Colson Group. Specifications subject
to change without notice. CGP305.0925.r2

Colson Group products labeled "Made in USA" are
manufactured and assembled in the United States
but may contain domestic and imported materials.

NEED HELP OR A QUOTE?

www.AlbionCasters.com